

# KRACHT®

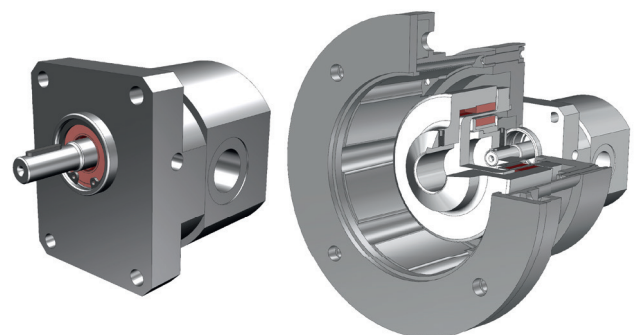

Gear pumps

**KF 0 stainless steel**  
with magnetic coupling

# Gear pumps KF 0 stainless steel

## Description

### Construction

#### Gear pump with rotary shaft seal

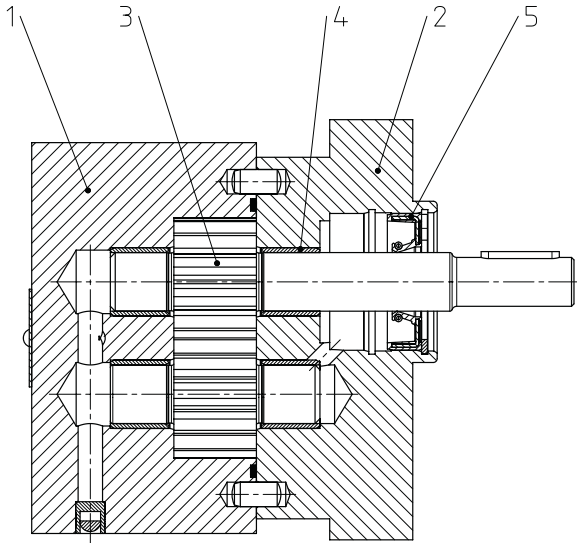

- 1 Housing
- 2 Flange cover
- 3 Gearing
- 4 Bearing bush
- 5 Rotary shaft seal

#### Gear pump with double rotary shaft seal and threaded connection for liquid seal (quench)

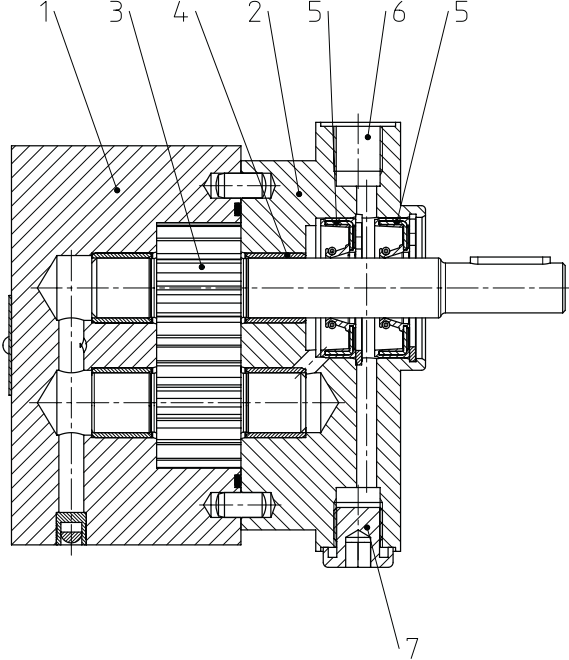

- 1 Housing
- 2 Flange cover
- 3 Gearing
- 4 Bearing bush
- 5 Double rotary shaft seal
- 6 Threaded flange for liquid seal (quench)
- 7 Threaded flange for liquid seal (quench)

## Description

### KF 0 stainless steel – a pump for process technology.

The dosing of liquids is the main task in numerous process engineering processes. PU components, plasticisers, resins, adhesives, lacquers and paints are some of the most important liquids with a wide range of applications. The accuracy, evenness and reproducibility with which these liquids can be processed are decisive for the quality of the end product.

The KF 0 stainless steel gear pump is particularly suitable for these applications. The KF 0 stainless steel is an external gear pump with flow rates of 1 cm<sup>3</sup>/rev to 4 cm<sup>3</sup>/rev. The grading of the total of 4 nominal sizes makes it easier to set the desired dosing ratios.

The fine gearing with a high number of teeth guarantees a low-pulsation volume flow.

In combination with a flow meter and the electronics the KF 0 stainless steel can be extended to a highly precise dosing unit.

Various types of seals, such as rotary shaft seals and double rotary shaft seals can be selected depending on the task, whereby the latter version enables operations with liquid seal (quench) to prevent the pumping medium from hardening or crystallising.

**Gear pumps KF 0 stainless steel**

**Technical data**

**Characteristics**

Mounting	Flange
Pipe connection	Pipe thread
Direction of rotation	Right <b>or</b> left
Mounting position	Arbitrary (see dimension sheets)

**Working characteristics**

Displacement (cm <sup>3</sup> /rev)	V <sub>g</sub> = 1.0 / 1.6 / 2.5 / 4.0
Working pressure inlet port	p <sub>e min</sub> = -0.4 bar (-0,6 bar short-term for start-up state) p <sub>e max</sub> = 2 bar
Working pressure outlet port	p <sub>n max</sub> = 60 bar (depending on medium, viscosity and delivery volume)
Speed	n = 3000 1/min (depending on the viscosity)
Viscosity	v <sub>min</sub> = 10 mm <sup>2</sup> /s v <sub>max</sub> = 20 000 mm <sup>2</sup> /s
Media temperature	ϑ <sub>m max</sub> = 150 °C (FKM) ϑ <sub>m max</sub> = 200 °C (PTFE)
Ambient temperature	ϑ <sub>u min</sub> = -20°C ϑ <sub>u max</sub> = 60°C

**Materials**

Housing	Stainless steel 1.4404
Bearing	Bearing bush
Bearing material	Plastic
Gearing	Stainless steel 1.4462 coated
Shaft seal	Rotary shaft seal FKM/PTFE Double rotary shaft seal FKM/PTFE
Free of non-ferrous metals	Yes

**Working pressure depends on the viscosity**

Nominal size	Perm. working pressure in bar for viscosity			
	10 mm <sup>2</sup> /s	30 mm <sup>2</sup> /s	100 mm <sup>2</sup> /s	>500 mm <sup>2</sup> /s
1.0	5	10	20	60
1.6	20	60	60	60
2.5	30	60	60	60
4.0	40	60	60	60

The values are valid for the speed range of n = 1000 ... 3000 rpm.  
Reduce the working pressures for speeds < 1000 rpm.

Type key

<b>KF 0/</b>	<b>2.5</b>	<b>S</b>	<b>1</b>	<b>0</b>	<b>K</b>	<b>P00</b>	<b>0QT</b>	<b>2/</b>	<b>516</b>
									<b>Special number for stainless steel design</b>
									<b>Seal</b>
									<b>2</b> FKM
									<b>32</b> PTFE
									<b>82</b> Liquid seal (quench) FKM
									<b>98</b> Liquid seal (quench) PTFE
									<b>0</b> Design code
									<b>Q</b> Housing material stainless steel
									<b>T</b> Type of gearing: Stainless steel spur toothed
									<b>P</b> Shaft end cylindrical
									<b>0</b> Without 2nd shaft end
									<b>0</b> Without end cover
									<b>Type of connection</b>
									<b>K</b> Pipe thread
									<b>Outboard flange</b>
									<b>0</b> Without angle foot
									<b>Direction of rotation</b>
									<b>1</b> Right
									<b>2</b> Left
									<b>Mounting</b>
									<b>S</b> Flange version
									<b>Nominal size</b>
									1.0 / 1.6 / 2.5 / 4.0
<b>Product name</b>									

Dimensions and weights

KF 0/ . S . 0K P00 0QT . /516

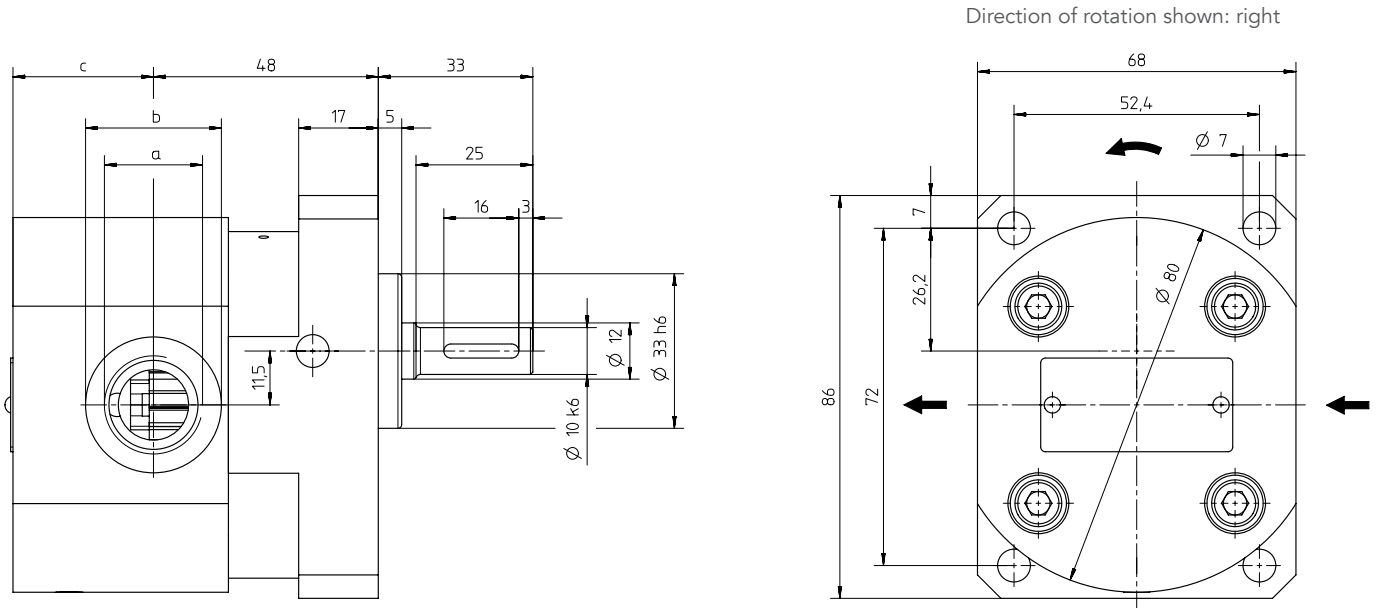

Inlet and outlet port connections are dimensionally the same

Parallel key  
A 3 x 3 x 16  
DIN 6885

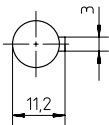

	Displacement in cm <sup>3</sup> /rev / Nominal size			
	1.0	1.6	2.5	4.0
a	G 3/8 – 13 deep	G 1/2 – 15 deep		
b	25	29		
c	25	20	25	30
Weight in kg	2.6	2.4	2.6	2.7

Dimensions and weights with liquid seal (quench)

KF 0/ . S . 0K P00 0QT . /516

Direction of rotation shown: right

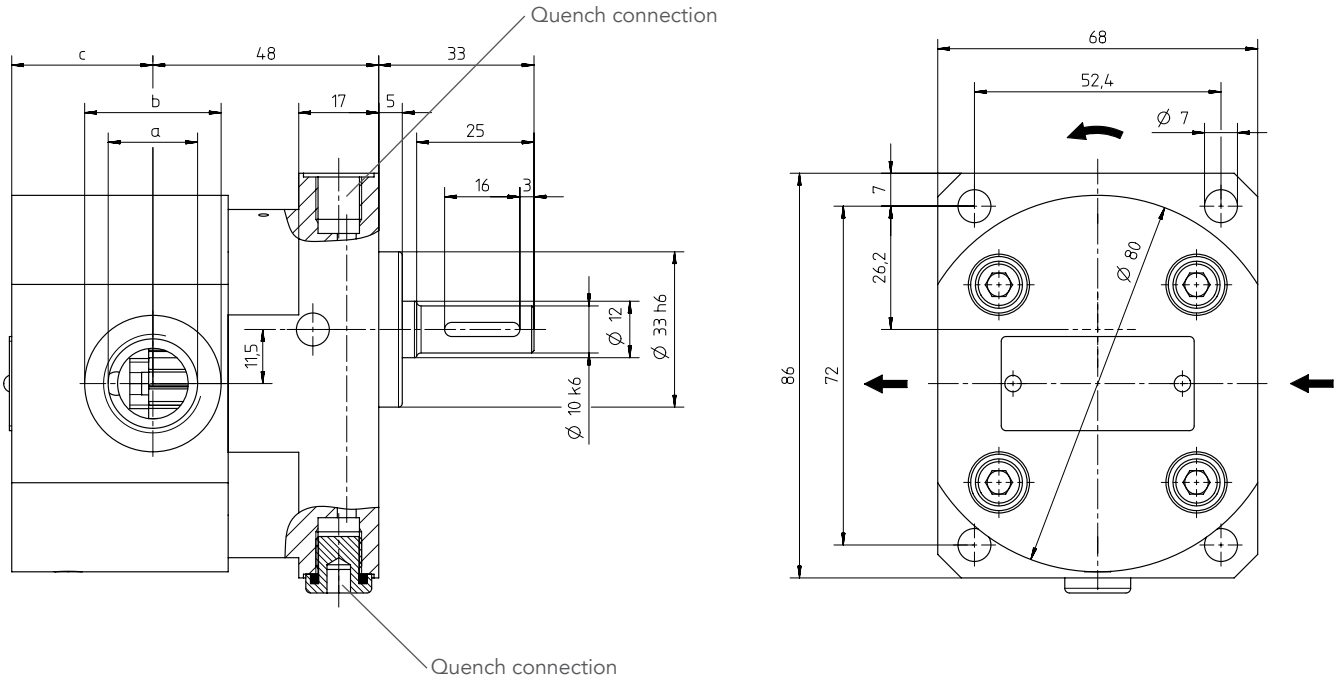

Inlet and outlet port connections are dimensionally the same

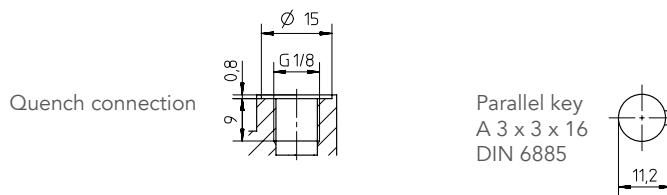

	Displacement in cm <sup>3</sup> /rev / Nominal size			
	1.0	1.6	2.5	4.0
a	G 3/8 – 13 deep	G 1/2 – 15 deep		
b	25	29		
c	25	20	25	30
Weight in kg	2.6	2.4	2.6	2.7

**Couplings**

**Dimensions**

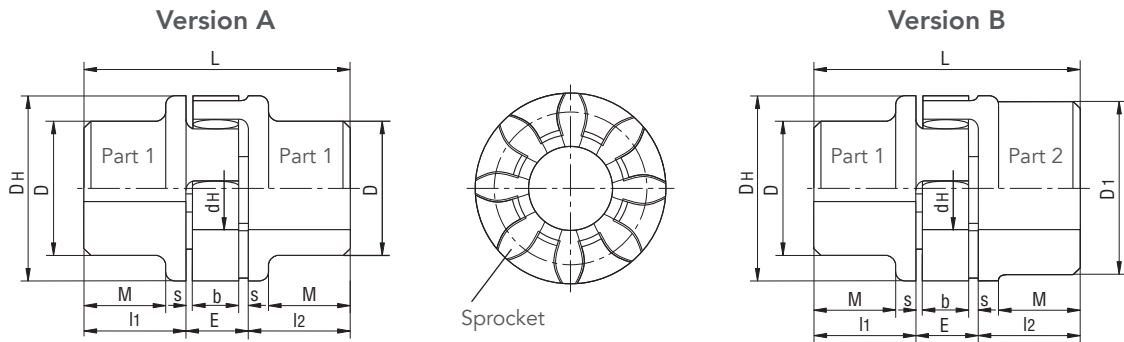

	Ordering code	Coupling size	Hub material (Al)		Finished bore				Dimensions									
			Weight kg	Mass inertia kgm <sup>2</sup>	min.		max.		l1/l2	E	s	b	L	M	D <sub>H</sub>	D	D <sub>1</sub>	d <sub>H</sub>
					Part 1	Part 2	Part 1	Part 2										
Version A	RA 14-Z 11/...-Z 11/..	14	0.045	0.000006	6	-	16	-	11	13	1.5	10	35	-	30	30	-	10
	RA 19-Z 25/...-Z 25/..	19	0.117	0.000023	6	-	19	-	25	16	2.0	12	66	20	41	32	-	18
Version B	RA 19/24-Z 25/...-Z 25/..	19/24	0.129	0.000033	6	19	19	24	25	16	2.0	12	66	20	41	32	41	18
	RA 24/28-Z 30/...-Z 30/..	24/28	0.290	0.000140	9	24	22	28	30	18	2.0	14	78	24	56	40	56	27

**Type key KF coupling**

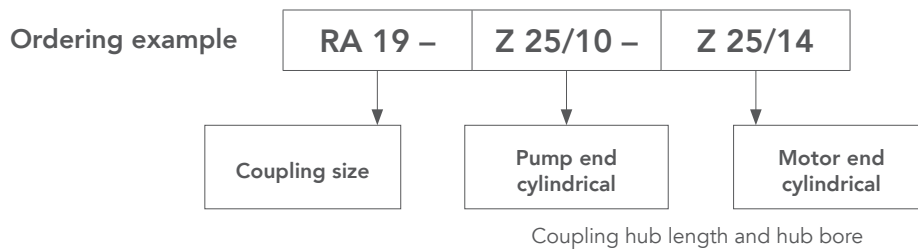

Working temperature:  
-20 ... 80 °C  
(short-term temperature peaks up to 120 °C are permissible)

Weights and mass moments of inertia refer to max. finished bore without keyway.  
Finished bore according to H7;  
Parallel keys according to DIN 6885 Sh. 1

**Bell housing**

KF 0 Aluminium bell housing

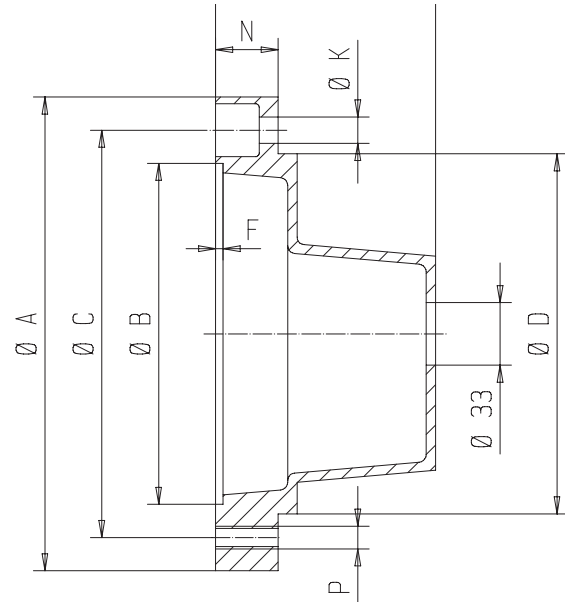
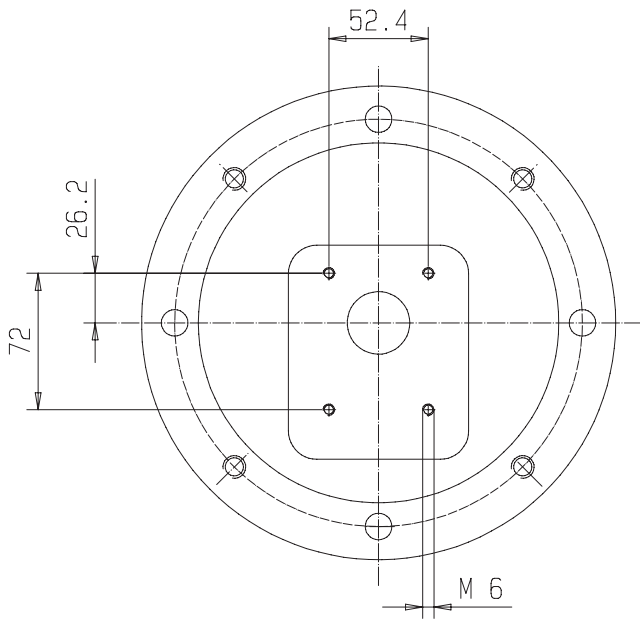

Motor size	Bell housing	Coupling	Dimensions									Weight kg
			A	B	C	D	F	K	L	N	P	
63	Z0/140/70	RA14-Z11/10-Z11/11	140	95	115	95	4	9	70	17	M8	0.360
71 S	Z0/160/80	RA19-Z25/10-Z25/14	160	110	130	110	4	9	80	13	M8	0.490
71												
80 S	Z0/200/90	RA19-Z25/10-Z25/19	200	130	165	145	5	11	90	16	M10	0.600
80												
90 S	Z0/200/100	RA19/24-Z25/10-Z25/24	200	130	165	145	4	11	100	27	M10	1.345
90 L												
100 LS	Z0/250/116	RA24/28-Z30/10-Z30/28	250	180	215	190	4	14	116	33	M12	1.400
100 L												
112 M												

Dimensions in mm



# Gear pumps KF 0 stainless steel with magnetic coupling

## Description

### Constuction

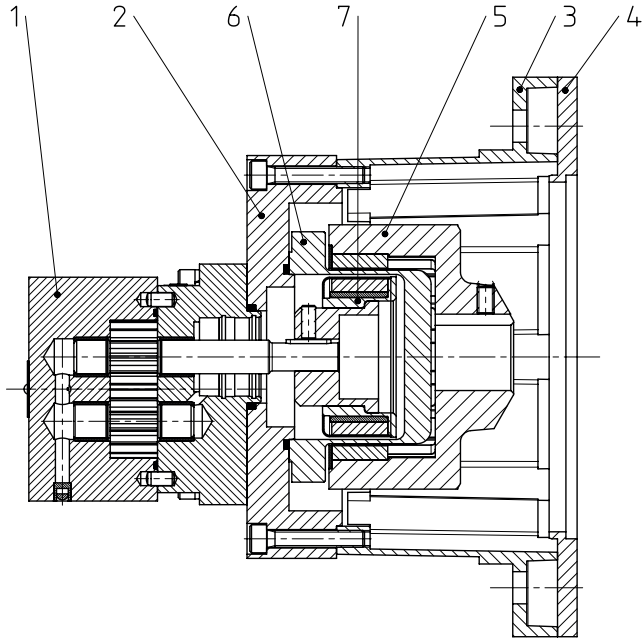

- 1 Pump
- 2 Adapter
- 3 Bell housing
- 4 Adapter
- 5 Outer rotor
- 6 Split case
- 7 Inner rotor

### Description

With various applications conventional seals come up against their limits. Typical applications can be found in PUR plants, refrigerating installations and vacuum plant. It is possible to fit the KF 0 with a magnetic coupling for these applications.

The magnetic coupling serves as a shaft seal and to transmit the torque. The outer rotor of the magnetic coupling is placed on the motor shaft and the inner rotor directly on the pump shaft.

The torque is transmitted between the outer and inner rotors through the magnetic forces. The split case, which seals the pump hermetically, is located between the two rotors.

The magnetic coupling is used if an absolutely tight seal is required between the pump chamber and the atmosphere, e.g. for dosing isocyanate, where contact with the air would lead to an undesired hardening of the medium. It can be used in vacuum operations, e.g. filling brake liquid, and reliably prevents air penetrating into the system. Non-leak operations are also guaranteed when used in sealed systems with a high admission pressure on the pump suction side.

The magnetic coupling is predestined for dosing hazardous and harmful media.

## Technical data

### Characteristics

Mounting	Flange
Pipe connection	Pipe thread
Direction of rotation	Right <b>or</b> left
Mounting position	Horizontal

## Technical data

### Working characteristics

Displacement in cm <sup>3</sup> /rev	V <sub>g</sub>	1.0 / 1.6 / 2.5 / 4.0
Working pressure inlet port	p <sub>e min</sub> p <sub>e max</sub>	= -0.4 bar, Vacuum system -0.92 bar = MSA 46: 16 bar MSA 60: 40 bar MSB 60: 40 bar
Working pressure outlet port	p <sub>n max</sub>	= 100 bar / max Δp = 60 bar
Speed	n	= 3000 1/min (depending on the viscosity)
Viscosity	v <sub>min</sub> v <sub>max</sub>	= 10 mm <sup>2</sup> /s = 20 000 mm <sup>2</sup> /s
Media temperature	ϑ <sub>m min</sub> ϑ <sub>m max</sub> ϑ <sub>m max</sub>	= -15 °C = 150 °C (FKM) = 150 °C (PTFE)
Ambient temperature	ϑ <sub>u min</sub> ϑ <sub>u max</sub>	= -15°C = 60°C

### Materials

Inner rotor	Stainless steel 1.4571
Split case	Stainless steel 1.4571
Outer rotor	5355S2 (St 52)
Magnets	Sm2Co17
Adapter flange	Stainless steel 1.4571

### Magnetic coupling torques

MSA 46/6	3 Nm
MSA 60/8	7 Nm
MSB 60/8	14 Nm

### Selection Assistance

Pump	Coupling size	Perm. power in kW at n = 750 1/min	Motor size	Perm. power in kW at n = 1000 1/min	Motor size	Perm. power in kW at n = 1500 1/min	Motor size	Perm. power in kW at n = 3000 1/min	Motor size
KF 0	MSA 46	0.12	71	0.18	71	0.12	63	0.25	63
		-	-	-	-	0.18	63	0.37	71
		-	-	-	-	0.25	71	0.55	71
	MSA 60	0.18	80	0.25	71	0.37	71	0.75	80
		0.25	80	0.37	80	0.55	80	1.10	80
	MSB 60	0.37	90	0.55	80	0.75	80	1.50	90
		0.55	90	0.75	90	1.10	90	2.20	90

The values stated in the table refer to a maximum media temperature of 80 °C.  
For media temperatures >80 °C stronger magnetic couplings should be selected if necessary.

### The following data must be available for the design of a magnetic coupling:

- Pump size
- Pump pressure (working and start-up pressure)
- Working and start-up viscosity
- Exact media designation and properties
- Power of the drive motor
- Speed or speed range
- On phase - direct or with frequency converter
- Media and ambient temperature

Type key

<b>KF 0/2.5</b>	<b>S10K</b>	<b>P00</b>	<b>0QT</b>	<b>2/</b>	<b>516</b>	<b>MSA 46</b>	<b>A</b>	<b>1-160</b>								
								<table border="1"> <tr><th colspan="2">Motor flange</th></tr> <tr><td>160</td><td>Outer diameter (in mm)</td></tr> </table>	Motor flange		160	Outer diameter (in mm)				
Motor flange																
160	Outer diameter (in mm)															
								<table border="1"> <tr><th colspan="2">Max. permissible pressure in the split case</th></tr> <tr><td>1</td><td>16 bar</td></tr> <tr><td>3</td><td>40 bar</td></tr> </table>	Max. permissible pressure in the split case		1	16 bar	3	40 bar		
Max. permissible pressure in the split case																
1	16 bar															
3	40 bar															
								<table border="1"> <tr><th colspan="2">Max. magnetic coupling temperature</th></tr> <tr><td>A</td><td>150 °C</td></tr> </table>	Max. magnetic coupling temperature		A	150 °C				
Max. magnetic coupling temperature																
A	150 °C															
								<table border="1"> <tr><th colspan="2">Magnetic coupling size</th></tr> <tr><td>MSA 46</td><td>16 bar</td></tr> <tr><td>MSA 60</td><td>40 bar</td></tr> <tr><td>MSB 60</td><td>40 bar</td></tr> </table>	Magnetic coupling size		MSA 46	16 bar	MSA 60	40 bar	MSB 60	40 bar
Magnetic coupling size																
MSA 46	16 bar															
MSA 60	40 bar															
MSB 60	40 bar															
								<table border="1"> <tr><th colspan="2">Special number for stainless steel design</th></tr> <tr><td></td><td></td></tr> </table>	Special number for stainless steel design							
Special number for stainless steel design																
								<table border="1"> <tr><th colspan="2">Seal</th></tr> <tr><td>61</td><td>FKM</td></tr> <tr><td>63</td><td>PTFE</td></tr> </table>	Seal		61	FKM	63	PTFE		
Seal																
61	FKM															
63	PTFE															
								<table border="1"> <tr><td>0</td><td>Design code number</td></tr> <tr><td>Q</td><td>Housing material stainless steel</td></tr> <tr><td>T</td><td>Type of gearing: Stainless steel spur toothed</td></tr> </table>	0	Design code number	Q	Housing material stainless steel	T	Type of gearing: Stainless steel spur toothed		
0	Design code number															
Q	Housing material stainless steel															
T	Type of gearing: Stainless steel spur toothed															
								<table border="1"> <tr><td>P</td><td>Shaft end cylindrical</td></tr> <tr><td>0</td><td>Without 2nd shaft end</td></tr> <tr><td>0</td><td>Without end cover</td></tr> </table>	P	Shaft end cylindrical	0	Without 2nd shaft end	0	Without end cover		
P	Shaft end cylindrical															
0	Without 2nd shaft end															
0	Without end cover															
								<table border="1"> <tr><th colspan="2">Type of connection</th></tr> <tr><td>K</td><td>Pipe thread</td></tr> </table>	Type of connection		K	Pipe thread				
Type of connection																
K	Pipe thread															
								<table border="1"> <tr><th colspan="2">Outboard flange</th></tr> <tr><td>0</td><td>Without angle foot</td></tr> </table>	Outboard flange		0	Without angle foot				
Outboard flange																
0	Without angle foot															
								<table border="1"> <tr><th colspan="2">Direction of rotation</th></tr> <tr><td>1</td><td>Right</td></tr> <tr><td>2</td><td>Left</td></tr> </table>	Direction of rotation		1	Right	2	Left		
Direction of rotation																
1	Right															
2	Left															
								<table border="1"> <tr><th colspan="2">Mounting</th></tr> <tr><td>S</td><td>Flange version</td></tr> </table>	Mounting		S	Flange version				
Mounting																
S	Flange version															
								<table border="1"> <tr><th colspan="2">Nominal size</th></tr> <tr><td></td><td>1.0 / 1.6 / 2.5 / 4.0</td></tr> </table>	Nominal size			1.0 / 1.6 / 2.5 / 4.0				
Nominal size																
	1.0 / 1.6 / 2.5 / 4.0															
<b>Product name</b>																

## I Gear pumps

Low and high-pressure gear pumps for lubricating oil, hydraulic, process and test bench applications, fuel and metering systems.



## I Flow measurement

Gear, turbine and screw type flow meters and electronics for volume and flow, metering and consumption in the chemical industry, hydraulic, process and test bench technology.

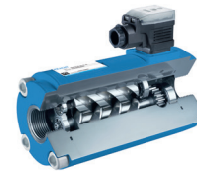

## I Hydraulics

Single and multistage high-pressure gear pumps, gear motors and valves for construction machinery, municipal vehicles, agricultural vehicles, special vehicles and truck bodies.



## I Valves

Pressure, quantity and flow valves in pipe and plate construction. Directional control and proportional valves according to Cetop. Hydraulic manifolds.



# KRACHT®

KRACHT GmbH · Gewerbestraße 20 · 58791 Werdohl, Germany  
Phone +49 2392.935 0 · Fax +49 2392.935 209  
Email [info@kracht.eu](mailto:info@kracht.eu) · Web [www.kracht.eu](http://www.kracht.eu)